

PRODUCT OPTION

INDEPENDENT SUSPENSION AXLE SYSTEM AX95

TECHNICAL DATA

Static Axle Load – Front	up to 12 000 kg
– Rear	up to 13 000 kg
Axle Differential Ratio	1,75
Wheel Gear Ratio	4,0
Overall Ratio	7,0
Maximum Input Torque	12 000 Nm
Maximum Input Speed	3 000 RPM
Suspension	Hydropneumatic
Total wheel travel	400mm
Maximum Wheel Angle Inside / Outside	35° / 28,5°
Differential Oil Capacity	7,5 l
Wheel Gear Oil Capacity	1,8 l
Oil Specification	SAE 75W-90, Multi-Purpose Gear Oil, API-GL-5 or MIL-L-2105C or CD
Max. Working Differential Temperature	120°C
Max. Working Temperature of Wheel Gear	100°C
Brake	Pneumatic Brakes Knorr, Ventilated Disc Ø432
Tyre	16.00 R20
Wheel Mount	20" 10-Bolt - Hub Piloted, 335mm (13,19")
Weight	Front Axle 950kg, Rear Axle 920kg, Drive Through Axle 1010kg

Option:

Suspension	Hydropneumatic with Height Management System option
Differential	Drive through differential with IAD 1:1
AWS	Remote electro-hydraulic steering

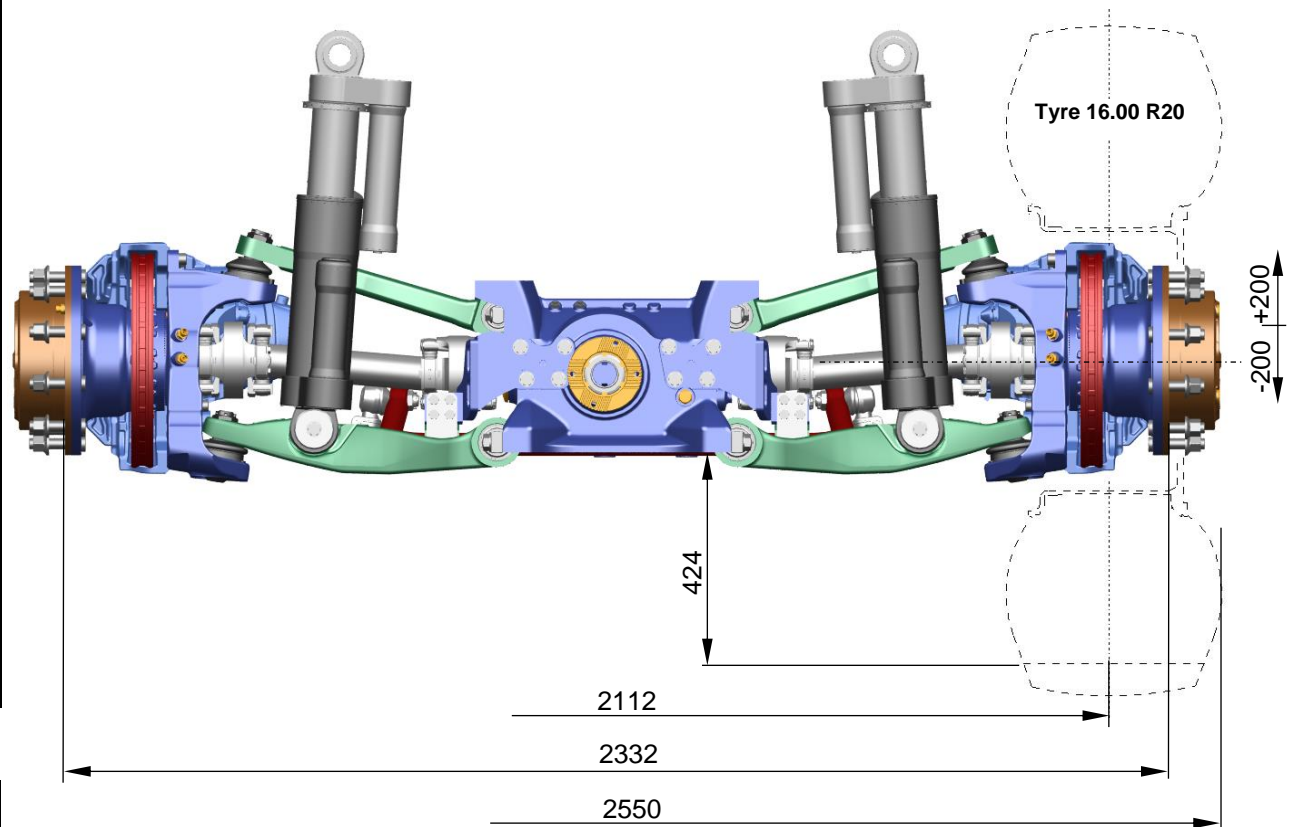

Address: Lubina 462, 742 21 Kopřivnice, CZECH REPUBLIC

Phone: +420 556 808 037, Fax: +420 556 808 685, vneuman@ads-cz.com, www.ads-cz.com

PRODUCT OPTION

INDEPENDENT SUSPENSION AXLE SYSTEM AX95

