

PRODUCT SPECIFICATION

TRANSFER CASE TC1000

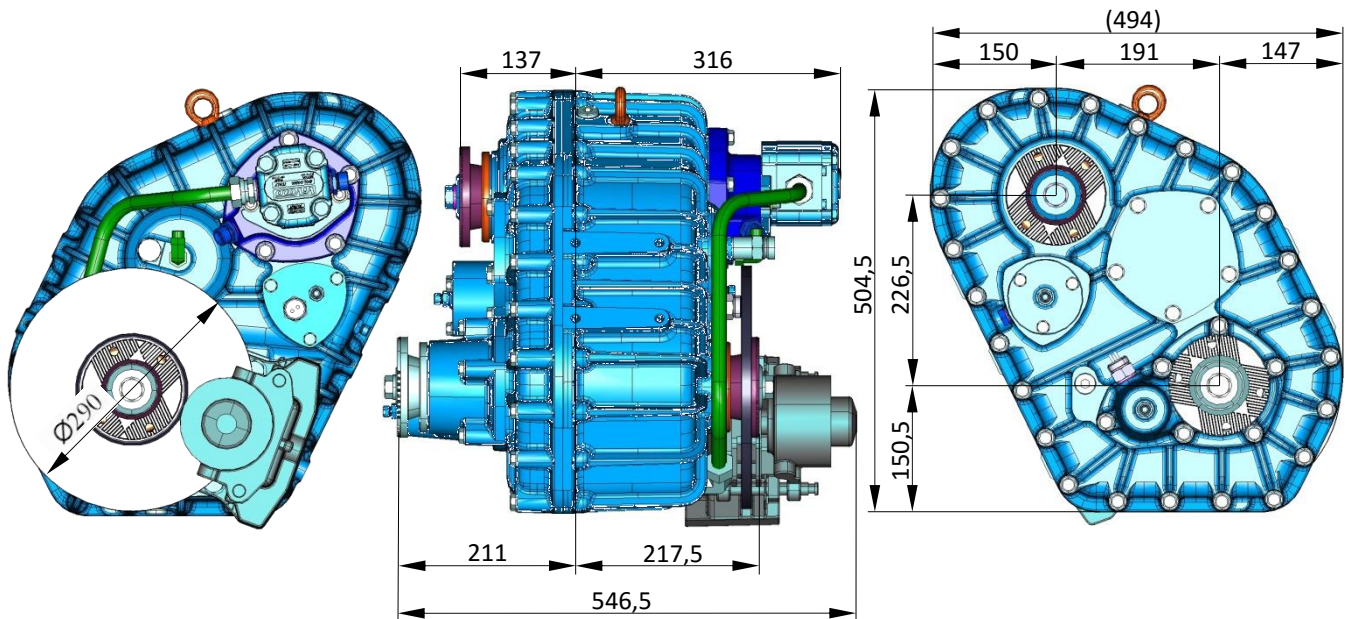

TECHNICAL DATA

Maximum Input Torque	10 000 Nm		
Maximum Input Speed version V1	3 450 RPM		
Total Offset Distance	298,2 mm		
High Speed Ratio	1,11		
Low Speed Ratio	1,94		
Split torque differential Ratio	34:66 with Lock		
Shifting –	air operated, electrical signal in high and low speed position air operated, electrical signal in differential lock on position air pressure 6,5÷8,0 bar		
Lubrication –	internal oil pump, possibility of external cooling circuit		
Oil Capacity	3,8 l – according oil level plug		
Oil Specification	SAE 75W-90, Multi-Purpose Gear Oil, API-GL-5 or MIL-L-2105C or CD		
Maximum Working Temperature	125°C		
Weight	162 Kg		
Flanges	Input	Front Axle	Rear Axle
	KV120	KV120	KV120
Parking Brake Type	KNOTT FSG90 102 709		
Disc Wheel Diameter	φ290mm		