

PRODUCT SPECIFICATION

TRANSFER CASE TCA852

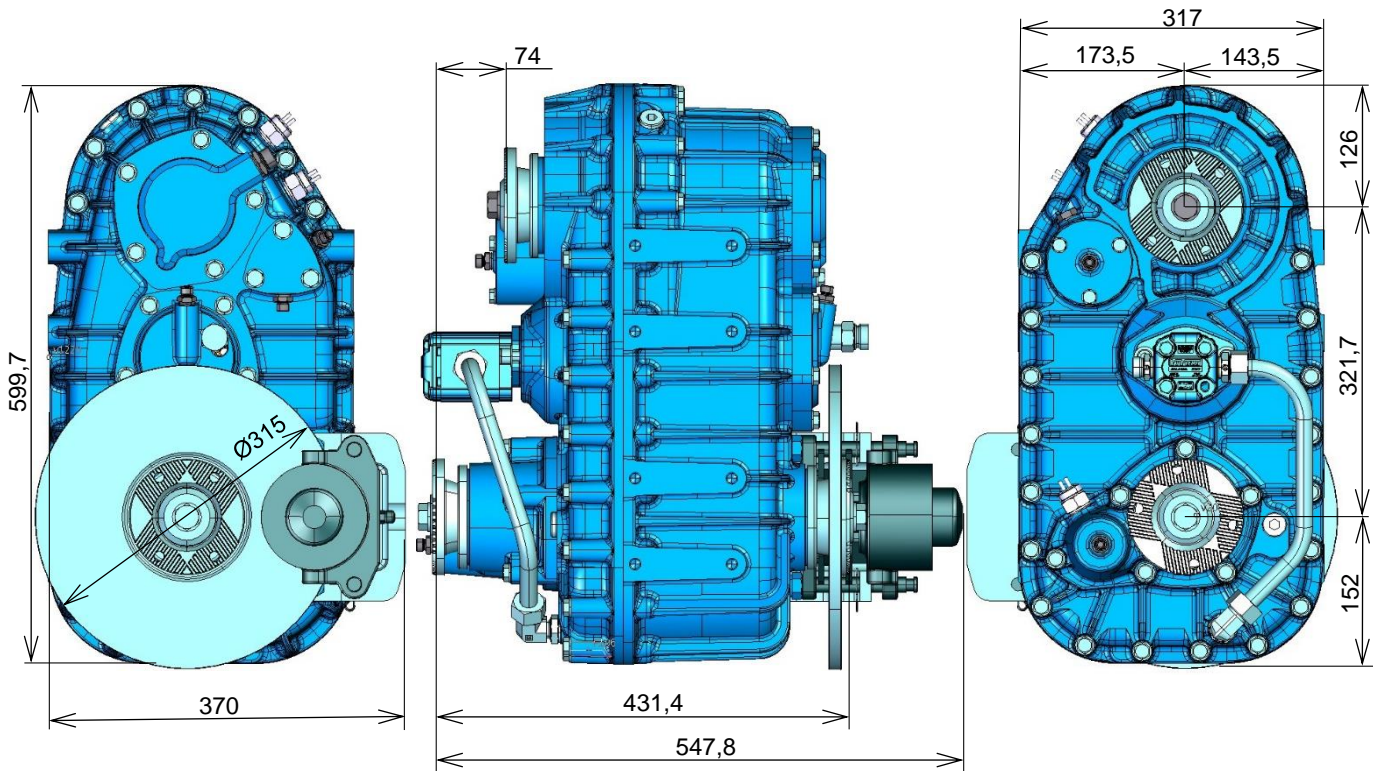

TECHNICAL DATA

Maximum Input Torque	8 000 Nm (10 000Nm)			
Maximum Input Speed version V1	3 600 RPM (4000 RPM)			
Total Offset Distance	321,7 mm			
High Speed Ratio	1,1			
Low Speed Ratio	1,94			
Split torque differential Ratio	34:66 with Lock			
Shifting –	air operated, electrical signal in high and low speed position air operated, electrical signal in differential lock on position air pressure 6,5÷9,5 bar			
Lubrication –	internal oil pump, possibility of external cooling circuit			
Oil Capacity	3,8 l			
Oil Specification	SAE 75W-90, Multi-Purpose Gear Oil, API-GL-5 or MIL-L-2105C or CD			
Maximum Working Temperature	130°C			
Weight	122 Kg without Parking Brake			
Flanges	Input Axle	Front Axle	Rear Axle	
	KV120	KV120	KV120	
Parking Brake Type	KNOTT FSG90			

Info in bracket - subject to approval by the manufacturer

Address: Lubina 462, 742 21 Kopřivnice, CZECH REPUBLIC

Phone: +420 556 808 037, Fax: +420 556 808 685, vneuman@ads-cz.com, www.ads-cz.com